

## HardieSoffit® Panel Product Description

### HARDIESOFFIT® PANELS

HardieSoffit® panels are 8-ft. and 12-ft. long, 1/4-in. thick factory-primed fiber-cement panels designed to be used on the underside of eaves as soffit material. HardieSoffit panels are available as vented or non-vented boards. Vented HardieSoffit panels provide 5 sq. in. of net free ventilation per lineal foot of soffit.

James Hardie offers HardieSoffit panels in a range of time-saving pre-cut widths common to rake and eave applications. HardieSoffit panels come in either a smooth finish or Select Cedarmill® textured finish. Check with your local dealer for product availability. HardieSoffit panels can be combined with HardieTrim® Fascia boards used for fascia rakes and frieze applications to complete the eaves detailing.

HardieSoffit panels are also available with ColorPlus® Technology. The ColorPlus® coating is a factory-applied, oven-baked finish available on a variety of James Hardie® siding and trim products. See your local dealer for details and availability of products, colors and accessories.

### HARDIESOFFIT® BEADED PORCH PANEL

HardieSoffit Beaded Porch Panel is a decorative fiber cement panel to be used as ceiling on the underside of porches or eaves as exterior panel materials. HardieSoffit beaded porch panel is 1/4-in. thick, 4 ft. wide, 8 ft. in length, and has 2" OC beads, and comes with PrimePlus® factory primer and sealer. Must be finished with 100% acrylic paint. See your local dealer for details and availability of products, colors and accessories.



**HardieSoffit Non-Vented – Smooth**



**HardieSoffit Vented – Cedar-mill®**



**HardieSoffit Vented – Smooth**



**HardieSoffit Non-Vented – Cedar-mill®**



**HardieSoffit Beaded Porch Panel**



**HardieSoffit Beaded Porch Panel**

**HardieSoffit Non-Vented – Smooth**



**HardieSoffit Vented – Smooth**

# Installation of HardieSoffit® Panels

## INSTALLATION OF HARDIESOFFIT® PANELS

HardieSoffit® panels must be attached to solid framing such as 2x4 supports spaced no more than 24 in. o.c. For eaves install HardieSoffit panels with the long edge of the panel perpendicular to the ends of the rafters or joists. Eaves framing must include a subfascia, blocking, and/or ledger board to provide solid nailing along the long dimension of the soffit. All panel edges must be supported.

For rake overhangs 2x “look outs” spaced a maximum of 24 in. o.c. should support a rake subfascia to provide adequate nailing for the rake soffit. Blocking between the lookouts provides support for the rake soffit along the building.

### 9.1 Soffit Framing

All edges of the soffit panels must be supported

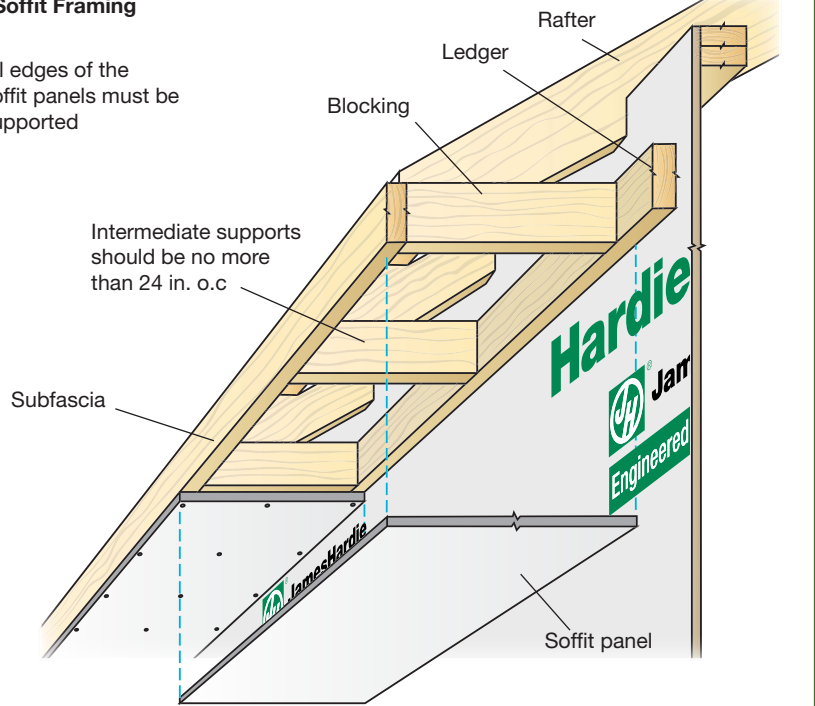

**TIP:** To aid in soffit panel installation, make a “deadman” or “third hand” post to help hold and position the soffit panel. Factory built tools such as those made for drywall installation are available, or they can be fabricated from lumber on the job-site.

## JOINT TREATMENT FOR HARDIESOFFIT PANELS

There are several ways to join the lengths of HardieSoffit panels. Panel ends may be lightly butted in moderate contact, the ends may be gapped  $\frac{1}{8}$  in. and caulked, joints can be covered with batten strips, or panels may be joined with PVC or metal H molding type connectors.

### 9.2

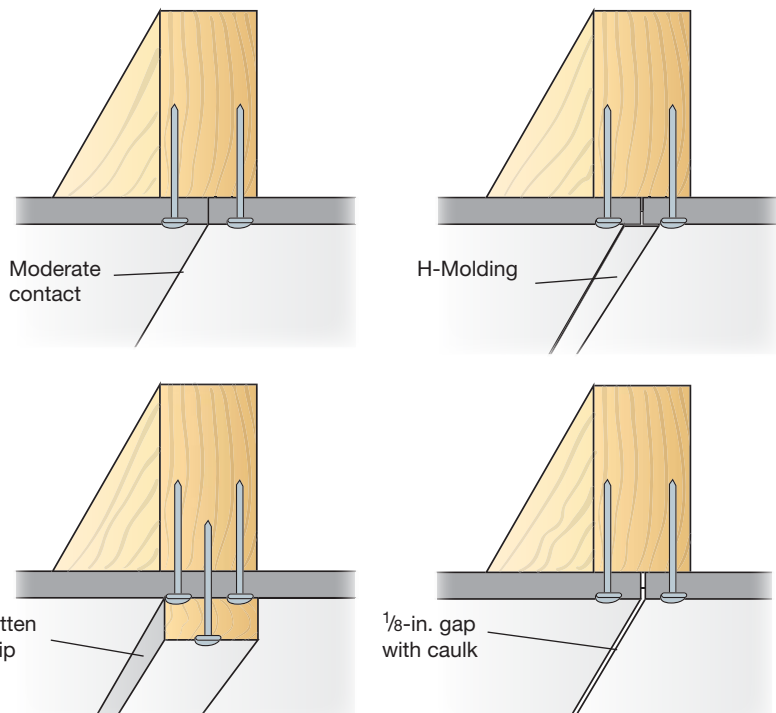

## FRAMING PREP FOR SOFFIT PANELS

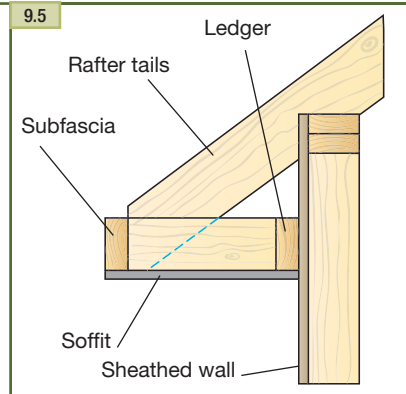
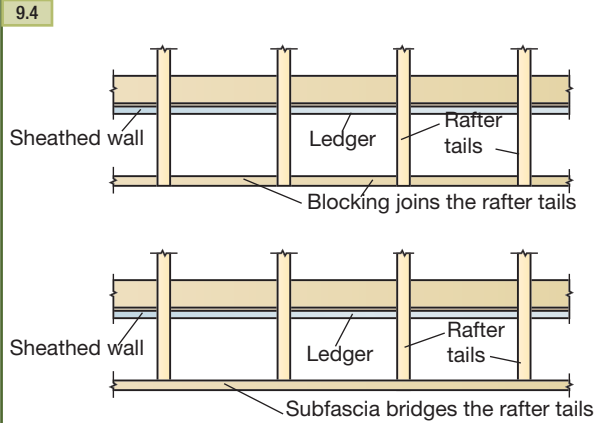
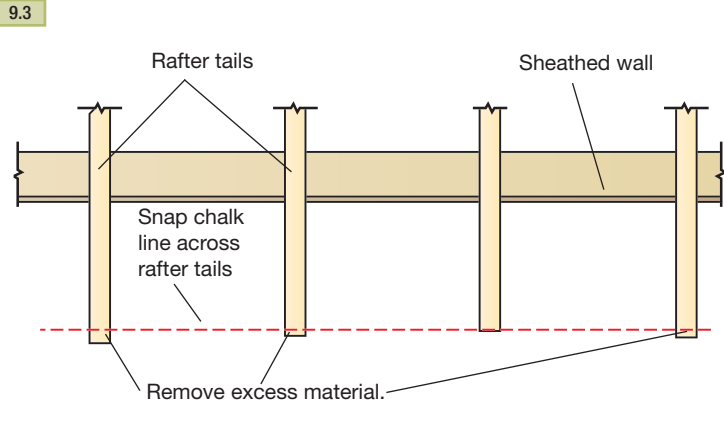

When installing the soffit:

- 1) Straighten the rafter tails by pulling and snapping a chalk line across the ends of the tails and then trimming them as necessary.
- 2) Install a solid wood sub-fascia on the ends of the rafter tails or install blocking between the rafter tails as needed.
- 3) If the soffit is to be installed level across its width, add nailers at every rafter or truss to provide support.
- 4) If the eaves are longer than 12 ft., measure and trim the first HardieSoffit® panel making sure that the end falls in the middle of a nailer.
- 5) Using the subfascia as a guide along the edge, carefully position the panel and secure with 4d common galvanized nails spaced no greater than 8 in. o.c. at all panel edges and on all intermediate framing members.
- 6) Continue with additional pieces until the run is complete.

## CUTTING 45° HIP ROOF SOFFITS

Hip roof soffits continue level around the corners of a house. The soffit panels should join at the corner with 45° angle cuts. To create these corners:

- 1) First measure from the corner to the perpendicular framing member closest to, but not over 12 ft.
- 2) Using that measurement and pulling from the factory cut end of the soffit panel, mark the outside edge of the soffit panel for the long point of the 45° cut.
- 3) After cutting the 45° angle, position the panel on the soffit framing and check the fit on both ends before fastening.
- 4) Begin nailing at the 45° cut end and work toward the factory end.

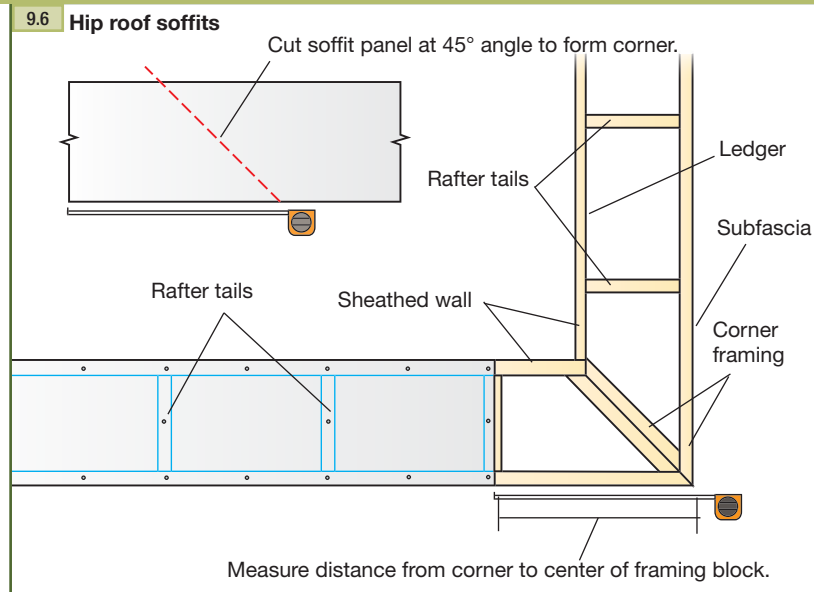

## WARNING

When using vented soffit, place the vented section of the panel toward the outside of the eave for optimum airflow.

# Installation of HardieSoffit® Panels (continued)

## INSTALLING FRIEZE BOARDS

### FRIEZE MADE FROM HARDIETRIM® 5/4, 4/4 BOARDS

When using lap and shingle sidings, install HardieTrim 5/4, 4/4 boards as a frieze board before putting in the siding. Then run courses of siding up to the frieze board and caulk the junction of the frieze board and siding. In a building sided with HardiePanel siding, the frieze board is commonly over the panel siding. If joints in the HardieTrim boards frieze are necessary for longer runs, join boards with a bevel cut. Nail the frieze board every 16 in. using finish or siding nails.

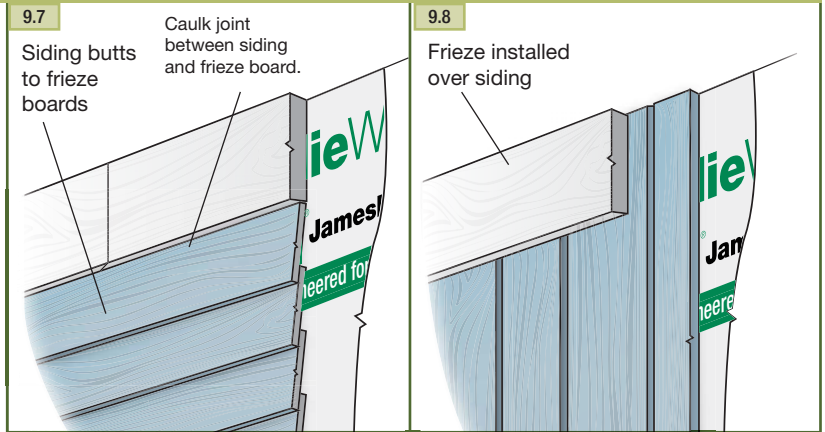

## TREATMENT OPTIONS FOR THE SIDING/SOFFIT JUNCTURE

In addition to the frieze board treatments described above, there are several other options for finishing the juncture where the siding meets the soffit.

### CAULK THE SIDING/SOFFIT JOINT

A fast and economical method of finishing the siding/soffit juncture is simply to run a bead of quality caulk along the top edge of the siding where it meets the soffit. A straight rip cut along the top edge of the siding ensures an aesthetically pleasing fit where it meets the soffit.

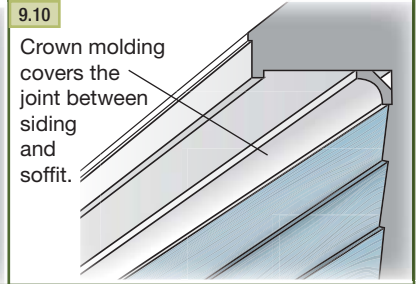
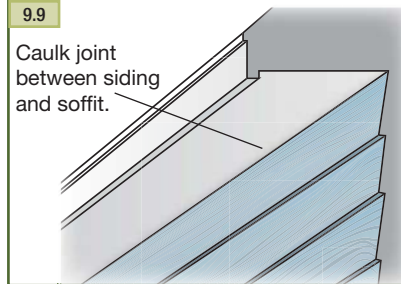

### INSTALL CROWN MOLDING

Crown molding is another way of finishing and sealing the soffit/siding juncture. Install and finish the crown molding according to the manufacturer's specifications.

### OVER THE TOP OF THE SIDING WITH 'J' CHANNEL

Once the soffit is in place, install a vinyl "J" channel upside down with the base of the "J" against the soffit. Then rip the final course of siding so that it fits inside the channel.

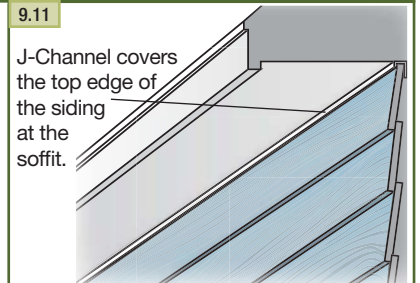

## INSECT SCREEN

In areas where additional insect protection is desired, a screen may be applied to the back side of the panel prior to soffit installation. After the screen type and size is selected, cut the screen to fit so that it covers the vent holes and overlaps the non-vented area of the soffit by 1 in. to 2 in. Secure the screen to the backside of the soffit panel using a bead of construction adhesive.

**TIP:** Stainless steel fasteners are recommended when installing James Hardie® products.

## HARDIESOFFIT® PANEL FASTENER SPECIFICATIONS

The Fastener Specifications table shows fastener options for a variety of different nailing substrates. Please refer to the applicable ESR report online (see back page) to determine which fastener meets your wind load design criteria.

Fastening Substrate	Approved Fastener	Fastening Types
wood studs	16" o.c.	① ⑥
	22.5" o.c.	⑥
	24" o.c.	①
steel studs	16" o.c.	⑦

①		4d common
⑥		ring shank siding nail
⑦		screw

**WARNING**

Please note that the addition of an insect screen reduces the total amount of vent area of the soffit depending on the size screen used.

# Installation of HardieSoffit® Beaded Porch Panels

General Product Information

Working Safety

Tools for Cutting and Fastening

General Installation Requirements

General Fastener Requirements

Finishing and Maintenance

HardieWrap® Weather Barrier

HardieTrim® Boards/Battens

HardieSoffit® Panels

HardiePlank® Lap Siding

HardieShingle® Siding

HardiePanel® Vertical Siding

Appendix/Glossary

ESR-1844 & 2290 Report

## BEADED PORCH PANEL FRAMING

HardieSoffit Beaded Porch Panel must be attached to either steel or wood normal 2x4 framing members spaced a maximum 24 in on center. All edges must be supported by framing.

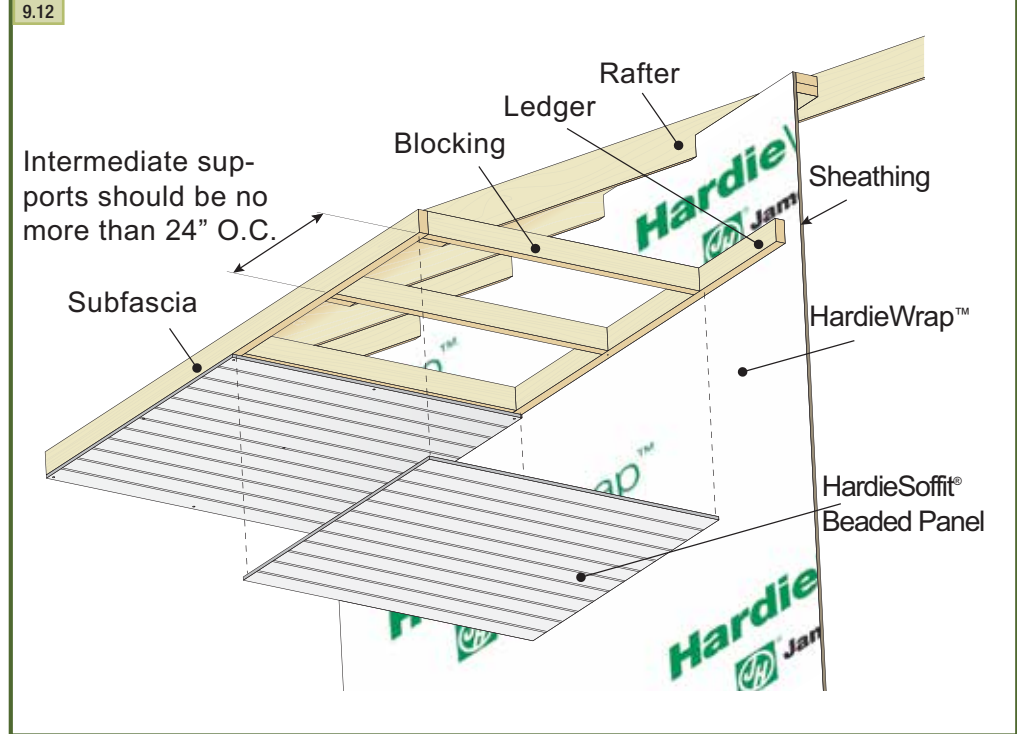

**TIP:** Stainless steel fasteners are recommended when installing James Hardie products near the ocean, large bodies of water, or in very humid climates.

## JOINT TREATMENT FOR BEADED PORCH PANEL

There are several ways to treat the joints of HardieSoffit beaded porch panels. The panel edges can be butted in moderate contact, leave a gap and caulk; or joints can be covered with Hardietrim batten strips.

**TIP:** Do not use finish nails for HardieSoffit beaded porch panel installation.

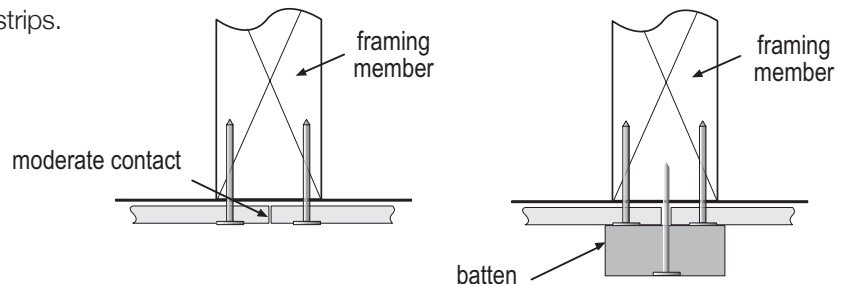

# Installation of HardieSoffit® Beaded Porch Panels (continued)

## HANDLING DURING INSTALLATION

Special precautions may be needed for carrying the panel during installation because of its larger size. James Hardie recommends the use of a T shape frame to support the panel during installation.



## SIDING/BEADED PORCH PANEL JOINT

A fast and economical method of finishing the siding/porch panel juncture is simply to run a bead of quality caulk along the top edge of the siding where it meets the soffit. A straight rip cut along the top edge of the siding ensures an aesthetically pleasing fit where it meets the beaded porch panel.

9.13

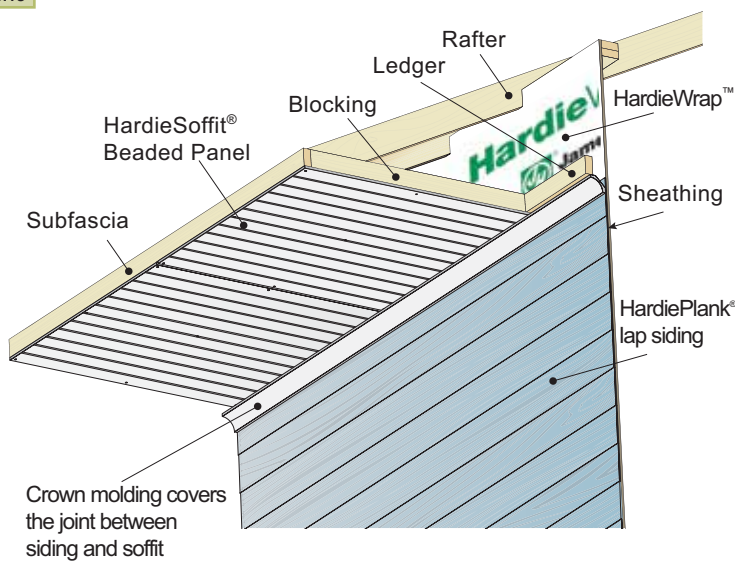

9.14

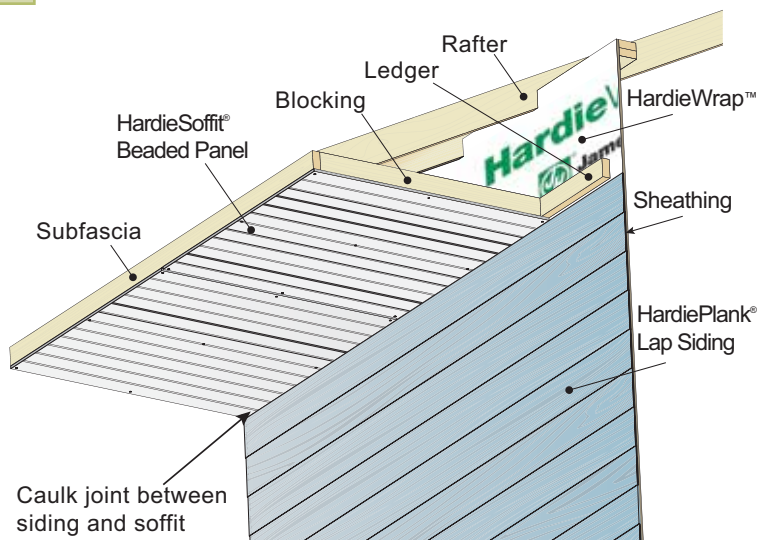

## INSTALLATION REQUIREMENTS - PRIMED & COLORPLUS® PRODUCTS

**IMPORTANT: FAILURE TO INSTALL AND FINISH THIS PRODUCT IN ACCORDANCE WITH APPLICABLE BUILDING CODES AND JAMES HARDIE WRITTEN APPLICATION INSTRUCTIONS MAY LEAD TO PERSONAL INJURY, AFFECT SYSTEM PERFORMANCE, VIOLATE LOCAL BUILDING CODES, AND VOID THE PRODUCT ONLY WARRANTY. BEFORE INSTALLATION, CONFIRM THAT YOU ARE USING THE CORRECT HARDIEZONE INSTRUCTIONS. INSTALLATION OF HZ10™ PRODUCTS OUTSIDE AN HZ10® LOCATION WILL VOID YOUR WARRANTY. TO DETERMINE WHICH HARDIEZONE APPLIES TO YOUR LOCATION, VISIT [WWW.HARDIEZONE.COM](http://WWW.HARDIEZONE.COM) OR CALL 1-866-942-7343 (866 9HARDIE)**

### STORAGE & HANDLING:

Store flat and keep dry and covered prior to installation. Installing siding wet or saturated may result in shrinkage at butt joints. Carry product on edge. Protect edges and corners from breakage. James Hardie is not responsible for damage caused by improper storage and handling of the product.

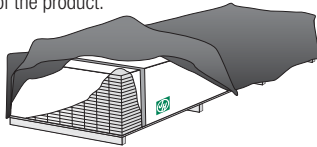

### CUTTING INSTRUCTIONS

#### OUTDOORS

- Position cutting station so that wind will blow dust away from user and others in working area.
- Use one of the following methods:
  - Best:
    - Score and snap
    - Shears (manual, electric or pneumatic)
  - Better:
    - Dust reducing circular saw equipped with a HardieBlade® saw blade and HEPA vacuum extraction
  - Good:
    - Dust reducing circular saw with a HardieBlade saw blade (only use for low to moderate cutting)

#### INDOORS

- Cut only using score and snap, or shears (manual, electric or pneumatic).
  - Position cutting station in well-ventilated area
- NEVER use a power saw indoors
  - NEVER use a circular saw blade that does not carry the HardieBlade saw blade trademark
  - NEVER dry sweep – Use wet suppression or HEPA Vacuum

Important Note: For maximum protection (lowest respirable dust production), James Hardie recommends always using "Best"-level cutting methods where feasible.

NIOSH-approved respirators can be used in conjunction with above cutting practices to further reduce dust exposures. Additional exposure information is available at [www.jameshardie.com](http://www.jameshardie.com) to help you determine the most appropriate cutting method for your job requirements. If concern still exists about exposure levels or you do not comply with the above practices, you should always consult a qualified industrial hygienist or contact James Hardie for further information.

SD083105

### GENERAL REQUIREMENTS:

- HardieSoffit® panels may be installed over either steel or wood framing complying with the local building code. See general fastener requirements. Install soffits to nominal 2 x 4 framing members spaced a maximum of 24 inches on center (fig.4),
- All edges must be supported by framing. (figs. 3 & 4)
- Install water barriers and air barriers as required by local building codes. James Hardie will assume no responsibility for moisture infiltration.
- Ensure gutters have end caps. Maintain a minimum 1" gap between end caps and siding & trim (fig.5).
- Install kickout flashing at roof-wall junctions. (fig 6.)
- DO NOT use stain, oil/alkyd base paint, or powder coating on James Hardie® Products.

### INSTALLATION:

- HardieSoffit panels must be fastened to a solid, nailable substrate such as a wood 2x subfascia.
  - Additional framing may be needed to ensure proper fastening.
  - Soffits can be installed as shown in figure 1. Position the vent holes toward the outside of the eave for optimal airflow.
  - 12" to 24" wide Vented HardieSoffit panels, provide 5.0 square inches of net free ventilation per lineal foot.
  - Alternatively vents can be installed into non-vented soffit.
  - If necessary, an insect screen can be installed using construction adhesive.
- Note: net free ventilation will be reduced.

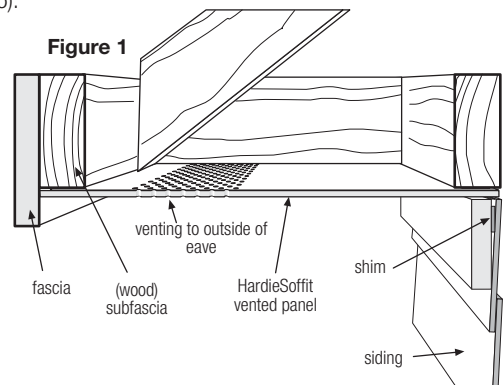

#### Fastener Requirements

- Position fasteners 3/8" from panel edges and no closer than 2" away from corners when using soffit greater than 12" wide (fig. 4) and no closer than 1" away from corners when using soffit that is less than or equal to 12" wide (fig. 3).

#### Joining Methods

- Install panels in moderate contact at ends, provide PVC or metal jointers, battens or leave appropriate gap and caulk (fig 2).

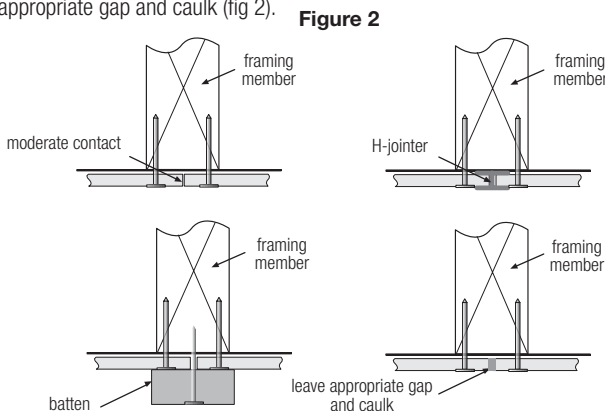

Figure 2

Figure 3

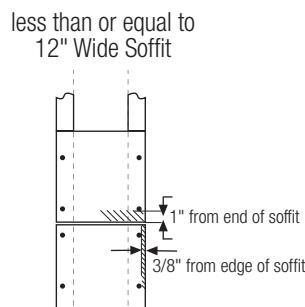
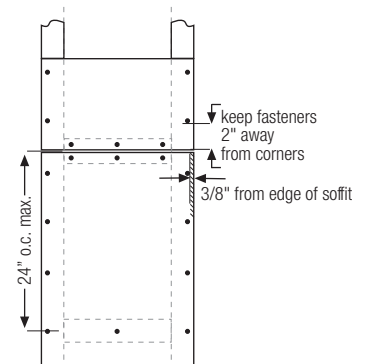

Figure 4

Greater than 12" Wide Soffit



1For additional information on HardieWrap™ Weather Barrier, consult James Hardie at 1-866-4Hardie or [www.hardiewrap.com](http://www.hardiewrap.com)

### WARNING: AVOID BREATHING SILICA DUST

James Hardie® products contain respirable crystalline silica, which is known to the State of California to cause cancer and is considered by IARC and NIOSH to be a cause of cancer from some occupational sources. Breathing excessive amounts of respirable silica dust can also cause a disabling and potentially fatal lung disease called silicosis, and has been linked with other diseases. Some studies suggest smoking may increase these risks. During installation or handling: (1) work in outdoor areas with ample ventilation; (2) use fiber cement shears for cutting or, where not feasible, use a HardieBlade saw blade and dust-reducing circular saw attached to a HEPA vacuum; (3) warn others in the immediate area; (4) wear a properly-fitted, NIOSH-approved dust mask or respirator (e.g. N-95) in accordance with applicable government regulations and manufacturer instructions to further limit respirable silica exposures. During clean-up, use HEPA vacuums or wet cleanup methods - never dry sweep. For further information, refer to our installation instructions and Material Safety Data Sheet available at [www.jameshardie.com](http://www.jameshardie.com) or by calling 1-800-9HARDIE (1-800-942-7343). FAILURE TO ADHERE TO OUR WARNINGS, MSDS, AND INSTALLATION INSTRUCTIONS MAY LEAD TO SERIOUS PERSONAL INJURY OR DEATH.

SD050905

Maintain a minimum 1" gap between gutter end caps and siding & trim.

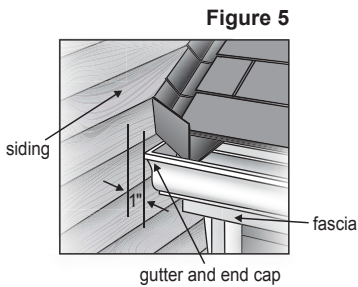
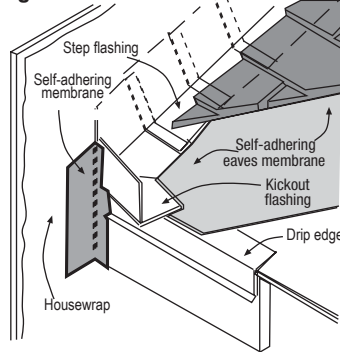

Figure 6



## KICKOUT FLASHING

Because of the volume of water that can pour down a sloped roof, one of the most critical flashing details occurs where a roof intersects a sidewall. The roof must be flashed with step flashing. Where the roof terminates, install a kickout to deflect water away from the siding. It is best to install a self-adhering membrane on the wall before the subfascia and trim boards are nailed in place, and then come back to install the kickout.

**Figure 6, Kickout Flashing** To prevent water from dumping behind the siding and the end of the roof intersection, install a "kickout" as required by IRC code R905.2.8.3 : "...flashing shall be a min. of 4" high and 4" wide." James Hardie recommends the kickout be angled between 100° - 110° to maximize water deflection

## FASTENER REQUIREMENTS

- For wood frame construction a minimum 4d common nails spaced 8" o.c. at panel edges and intermediate framing members spaced up to 24" on center are suitable in most locations\*.
- For conventional 20ga steel frame construction a minimum No. 8-18 x 0.323" HD x 1" long ribbed bugle screws spaced 6" o.c. at panel edges and intermediate framing members spaced up to 24" on center are suitable in most locations\*\*.

\*\*Minimum Basic Wind Speed differs by locality. Where specified levels of wind resistance are required, refer to applicable Building Code Compliance Reports.

## PNEUMATIC FASTENING

James Hardie products can be hand nailed or fastened with a pneumatic tool. Pneumatic fastening is highly recommended. Set air pressure so that the fastener is driven snug with the surface of the siding. A flush mount attachment on the pneumatic tool is recommended. This will help control the depth the nail is driven. If setting the nail depth proves difficult, choose a setting that under drives the nail. (Drive under driven nails snug with a smooth faced hammer - Does not apply for installation to steel framing).

## GENERAL FASTENING REQUIREMENTS

Fasteners must be corrosion resistant, galvanized, or stainless steel. Electro-galvanized are acceptable but may exhibit premature corrosion. James Hardie recommends the use of quality, hot-dipped galvanized nails. James Hardie is not responsible for the corrosion resistance of fasteners. Stainless steel fasteners are recommended when installing James Hardie® products near the ocean, large bodies of water, or in very humid climates..

- Consult applicable product evaluation or listing for correct fasteners type and placement to achieve specified design wind loads.
- NOTE: Published wind loads may not be applicable to all areas where Local Building Codes have specific jurisdiction. Consult James Hardie Technical Services if you are unsure of applicable compliance documentation.
- Drive fasteners perpendicular to siding and framing.
- Fastener heads should fit snug against siding (no air space). (fig. A)
- Do not over-drive nail heads or drive nails at an angle.
- If nail is countersunk, fill hole and add a nail. (fig. B)
- For wood framing, under driven nails should be hit flush to the plank with a hammer (For steel framing, remove and replace nail).
- **Do not use aluminum fasteners, staples, or clipped head nails.**

Snug



Figure A

Flush



Countersink, Fill & Add Nail



Figure B



do not under drive nails



DO NOT STAPLE



## CUT EDGE TREATMENT

Caulk, paint or prime all field cut edges. James Hardie touch-up kits are required to touch-up ColorPlus products.

## CAULKING

For best results use an Elastomeric Joint Sealant complying with ASTM C920 Grade NS, Class 25 or higher or a Latex Joint Sealant complying with ASTM C834. Caulking/Sealant must be applied in accordance with the caulking/sealant manufacturer's written instructions. **Note: OSI Quad as well as some other caulking manufacturers DO NOT allow tooling.**

## PAINTING

DO NOT use stain, oil/alkyd base paint, or powder coating on James Hardie® Products. James Hardie products must be painted within 180 days for primed product and 90 days for unprimed. 100% acrylic topcoats are recommended. Do not paint when wet. For application rates refer to paint manufacturers specifications. Back-rolling is recommended if the siding is sprayed.

## COLORPLUS® TECHNOLOGY CAULKING, TOUCH-UP & LAMINATE

- Care should be taken when handling and cutting James Hardie ColorPlus products. During installation use a wet soft cloth or soft brush to gently wipe off any residue or construction dust left on the product, then rinse with a garden hose.
  - Touch up nicks, scrapes and nail heads using the ColorPlus® Technology touch-up applicator. Touch-up should be used sparingly.
  - If large areas require touch-up, replace the damaged area with new HardieSoffit® panel with ColorPlus Technology.
  - Laminate sheet must be removed immediately after installation of each course.
  - Terminate non-factory cut edges into trim where possible, and caulk. Color matched caulks are available from your ColorPlus dealer.
  - Treat all other non-factory cut edges using the ColorPlus Technology edge coaters, available from your ColorPlus® product dealer.
- Note:** James Hardie does not warrant the usage of third party touch-up or paints used as touch-up on James Hardie ColorPlus products.

Problems with appearance or performance arising from use of third party touch-up paints or paints used as touch-up that are not James Hardie touch-up, will not be covered under the James Hardie ColorPlus Limited Finish Warranty.

## PAINTING JAMES HARDIE® PRODUCTS WITH COLORPLUS® TECHNOLOGY

When repainting ColorPlus products, James Hardie recommends the following regarding surface preparation and topcoat application:

- Ensure the surface is clean, dry, and free of any dust, dirt, or mildew
- Repriming is normally not necessary
- 100% acrylic topcoats are recommended
- DO NOT use stain, oil/alkyd base paint, or powder coating on James Hardie® Products
- Apply finish coat in accordance with paint manufacturers written instructions regarding coverage, application methods, and application temperature
- DO NOT caulk nail heads when using ColorPlus products, refer to the ColorPlus touch-up section

RECOGNITION: HardieSoffit Panel complies with ASTM C1186 in so doing meets the Fiber-Cement Siding code requirements in the 2006 International Building Code® Section 1404.10 and 1405.15, the 2009/12 International Building Code Section 1404.10 and 1405.16 ; and the 2006/09/12 International Residential Code® for One- and Two-Family Dwellings Table R703.4 and section R703.10. HardieSoffit panel is also recognized for application in the following: State of Florida Product Approval FL13265, Dade County, Florida NOA No. 13-0311.07, U.S. Dept. of HUD Materials Release 1263, Texas Department of Insurance Product Evaluation EC-23, City of New York MEA 223-93-M, and California DSA PA-019. These documents should also be consulted for additional information concerning the suitability of this product for specific applications

© 2013 James Hardie Building Products, Inc. All rights reserved. TM, SM, and ® denote trademarks or registered trademarks of James Hardie Technology Limited. ® is a registered trademark of James Hardie Technology Limited.

Additional Installation Information, Warranties, and Warnings are available at [www.jameshardie.com](http://www.jameshardie.com)



## INSTALLATION REQUIREMENTS - PRIMED & COLORPLUS® PRODUCTS

**IMPORTANT: FAILURE TO INSTALL AND FINISH THIS PRODUCT IN ACCORDANCE WITH APPLICABLE BUILDING CODES AND JAMES HARDIE WRITTEN APPLICATION INSTRUCTIONS MAY LEAD TO PERSONAL INJURY, AFFECT SYSTEM PERFORMANCE, VIOLATE LOCAL BUILDING CODES, AND VOID THE PRODUCT ONLY WARRANTY. BEFORE INSTALLATION, CONFIRM THAT YOU ARE USING THE CORRECT HARDIEZONE INSTRUCTIONS. INSTALLATION OF HZ10® PRODUCTS OUTSIDE AN HZ10® LOCATION WILL VOID YOUR WARRANTY. TO DETERMINE WHICH HARDIEZONE APPLIES TO YOUR LOCATION, VISIT [WWW.HARDIEZONE.COM](http://WWW.HARDIEZONE.COM) OR CALL 1-866-942-7343 (866 9HARDIE)**

### STORAGE & HANDLING:

Store flat and keep dry and covered prior to installation. Installing siding wet or saturated may result in shrinkage at butt joints. Carry product on edge. Protect edges and corners from breakage. James Hardie is not responsible for damage caused by improper storage and handling of the product.

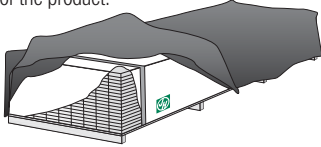

### CUTTING INSTRUCTIONS

#### OUTDOORS

1. Position cutting station so that wind will blow dust away from user and others in working area.
2. Use one of the following methods:
  - a. Best:
    - i. Score and snap
    - ii. Shears (manual, electric or pneumatic)
  - b. Better:
    - i. Dust reducing circular saw equipped with a HardieBlade® saw blade and HEPA vacuum extraction
  - c. Good:
    - i. Dust reducing circular saw with a HardieBlade saw blade (only use for low to moderate cutting)

#### INDOORS

1. Cut only using score and snap, or shears (manual, electric or pneumatic).
  2. Position cutting station in well-ventilated area
- NEVER use a power saw indoors
  - NEVER use a circular saw blade that does not carry the HardieBlade saw blade trademark
  - NEVER dry sweep – Use wet suppression or HEPA Vacuum

Important Note: For maximum protection (lowest respirable dust production), James Hardie recommends always using “Best”-level cutting methods where feasible.

NIOSH-approved respirators can be used in conjunction with above cutting practices to further reduce dust exposures. Additional exposure information is available at [www.jameshardie.com](http://www.jameshardie.com) to help you determine the most appropriate cutting method for your job requirements. If concern still exists about exposure levels or you do not comply with the above practices, you should always consult a qualified industrial hygienist or contact James Hardie for further information.

SD083105

### GENERAL REQUIREMENTS:

- HardieSoffit® beaded porch panels may be installed as a soffit or ceiling over either steel or wood framing complying with the local building code. See general fastening requirements. Install soffits to nominal 2 x 4 framing members spaced a maximum of 24 inches on center (fig.1), with the long dimension perpendicular to the rafter or joist framing.
- All edges must be supported by framing. (fig. 1)
- Install water barriers and air barriers as required by local building codes. James Hardie will assume no responsibility for moisture infiltration.
- DO NOT use stain, oil/alkyd base paint, or powder coating on James Hardie® Products.
- Ensure gutters have end caps. Maintain a minimum 1” gap between end caps and siding & trim (fig.5).
- Install kickout flashing at roof-wall junctions. (fig 6.)
- DO NOT use finish nails.

### INSTALLATION:

- HardieSoffit beaded porch panels must be fastened to a solid, nailable substrate such as wood.
- Additional framing may be needed to ensure proper fastening.
- Panels can be installed as shown in figure 1.

Figure 1

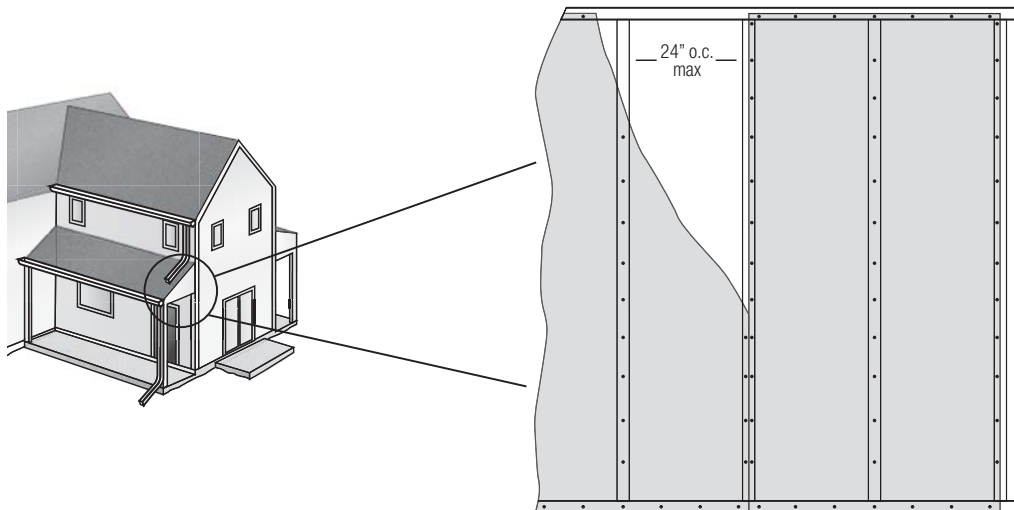

### WARNING: AVOID BREATHING SILICA DUST

James Hardie® products contain respirable crystalline silica, which is known to the State of California to cause cancer and is considered by IARC and NIOSH to be a cause of cancer from some occupational sources. Breathing excessive amounts of respirable silica dust can also cause a disabling and potentially fatal lung disease called silicosis, and has been linked with other diseases. Some studies suggest smoking may increase these risks. During installation or handling: (1) work in outdoor areas with ample ventilation; (2) use fiber cement shears for cutting or, where not feasible, use a HardieBlade® saw blade and dust-reducing circular saw attached to a HEPA vacuum; (3) warn others in the immediate area; (4) wear a properly-fitted, NIOSH-approved dust mask or respirator (e.g. N-95) in accordance with applicable government regulations and manufacturer instructions to further limit respirable silica exposures. During clean-up, use HEPA vacuums or wet cleanup methods - never dry sweep. For further information, refer to our installation instructions and Material Safety Data Sheet available at [www.jameshardie.com](http://www.jameshardie.com) or by calling 1-800-9HARDIE (1-800-942-7343). FAILURE TO ADHERE TO OUR WARNINGS, MSDS, AND INSTALLATION INSTRUCTIONS MAY LEAD TO SERIOUS PERSONAL INJURY OR DEATH.

SD050905

### Fastener Requirements

- Position fasteners 3/8" from panel edges and no closer than 2" away from corners (Figure 2).

Figure 2

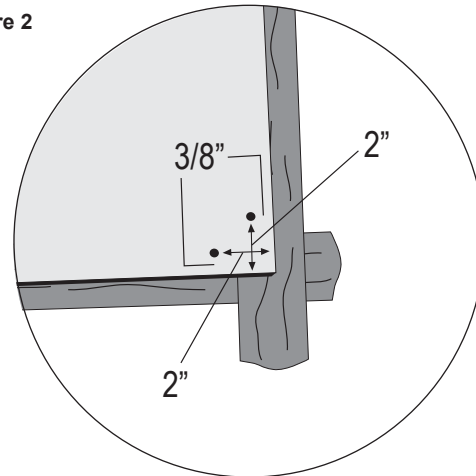

### Jointing Methods

- Panel ends are to be butted together as shown in Figure 3.
- Install panels in moderate contact at ends with or without battens (Figure 4).

Figure 3

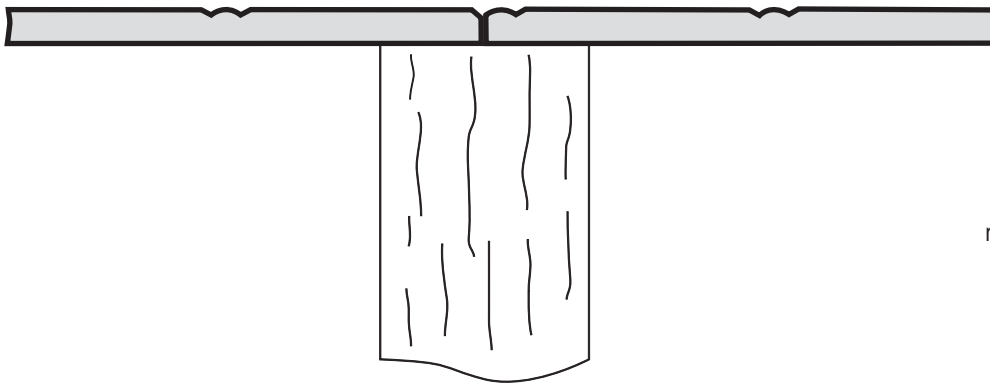
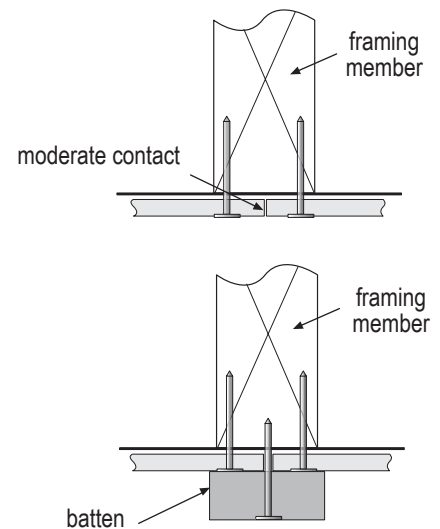

Figure 4



Maintain a minimum 1" gap between gutter end caps and siding & trim.

Figure 5

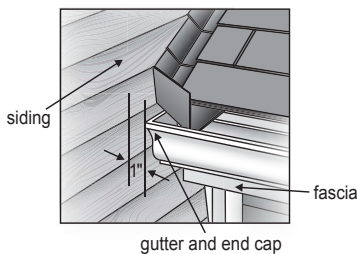
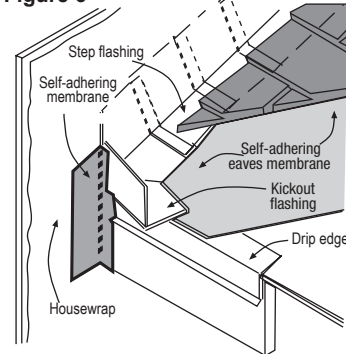

Figure 6



### KICKOUT FLASHING

Because of the volume of water that can pour down a sloped roof, one of the most critical flashing details occurs where a roof intersects a sidewall. The roof must be flashed with step flashing. Where the roof terminates, install a kickout to deflect water away from the siding.

It is best to install a self-adhering membrane on the wall before the subfascia and trim boards are nailed in place, and then come back to install the kickout.

**Figure 6, Kickout Flashing\*** To prevent water from dumping behind the siding and the end of the roof intersection, install a "kickout" of sufficient length and angle to direct the water running down the roof away from the siding.

\* The illustration (figure 6) was reprinted with permission of THE JOURNAL OF LIGHT CONSTRUCTION. For subscription information, visit [www.jlconline.com](http://www.jlconline.com).

## FASTENER REQUIREMENTS

- For wood frame construction a minimum 4d common nails spaced 8" o.c. at panel edges and intermediate framing members spaced up to 24" on center are suitable in most locations\*\*.
- For conventional 20ga steel frame construction a minimum No. 8-18 x 0.323" HD x 1" long ribbed bugle screws spaced 6" o.c. at panel edges and intermediate framing members spaced up to 24" on center are suitable in most locations\*\*.

\*\*Minimum Basic Wind Speed differs by locality. Where specified levels of wind resistance are required, refer to applicable Building Code Compliance Reports.

## GENERAL FASTENING REQUIREMENTS

Fasteners must be corrosion resistant, galvanized, or stainless steel. Electro-galvanized are acceptable but may exhibit premature corrosion. James Hardie recommends the use of quality, hot-dipped galvanized nails. James Hardie is not responsible for the corrosion resistance of fasteners. Stainless steel fasteners are recommended when installing James Hardie® products near the ocean, large bodies of water, or in very humid climates.

Manufacturers of ACQ and CA preservative-treated wood recommend spacer materials or other physical barriers to prevent direct contact of ACQ or CA preservative-treated wood and aluminum products. Fasteners used to attach HardieTrim Tabs to preservative-treated wood shall be of hot dipped zinc-coated galvanized steel or stainless steel and in accordance to 2009 IRC R317.3 or 2009 IBC 2304.9.5.

- Consult applicable code compliance report for correct fasteners type and placement to achieve specified design wind loads.
- NOTE: Published wind loads may not be applicable to all areas where Local Building Codes have specific jurisdiction. Consult James Hardie Technical Services if you are unsure of applicable compliance documentation.
- Drive fasteners perpendicular to siding and framing.
- Fastener heads should fit snug against siding (no air space). (fig. A)
- Do not over-drive nail heads or drive nails at an angle.
- If nail is countersunk, fill nail hole and add a nail. (fig. B)
- For wood framing, under driven nails should be hit flush to the plank with a hammer (For steel framing, remove and replace nail).
- NOTE: Whenever a structural member is present, HardiePlank should be fastened with even spacing to the structural member. The tables allowing direct to OSB or plywood should only be used when traditional framing is not available.
- **Do not use aluminum fasteners, staples, or clipped head nails.**

## PNEUMATIC FASTENING

James Hardie products can be hand nailed or fastened with a pneumatic tool. Pneumatic fastening is highly recommended. Set air pressure so that the fastener is driven snug with the surface of the siding. A flush mount attachment on the pneumatic tool is recommended. This will help control the depth the nail is driven. If setting the nail depth proves difficult, choose a setting that under drives the nail. (Drive under driven nails snug with a smooth faced hammer - Does not apply for installation to steel framing).

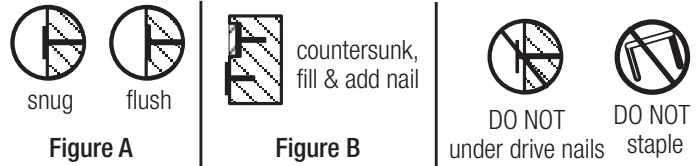

## PAINTING

DO NOT use stain, oil/alkyd base paint, or powder coating on James Hardie® Products. James Hardie products must be painted within 180 days for primed product and 90 days for unprimed. 100% acrylic topcoats are recommended. Do not paint when wet. For application rates refer to paint manufacturers specifications. Back-rolling is recommended if the siding is sprayed.

## CUT EDGE TREATMENT

Caulk, paint or prime all field cut edges. James Hardie touch-up kits are required to touch-up ColorPlus products.

## CAULKING

For best results use an Elastomeric Joint Sealant complying with ASTM C920 Grade NS, Class 25 or higher or a Latex Joint Sealant complying with ASTM C834. Caulking/Sealant must be applied in accordance with the caulking/sealant manufacturer's written instructions. **Note: OSI Quad as well as some other caulking manufacturers do not allow tooling.**

## COLORPLUS® TECHNOLOGY CAULKING, TOUCH-UP & LAMINATE

- Care should be taken when handling and cutting James Hardie ColorPlus products. During installation use a wet soft cloth or soft brush to gently wipe off any residue or construction dust left on the product, then rinse with a garden hose
- Touch up nicks, scrapes and nail heads using the ColorPlus® Technology touch-up applicator. Touch-up should be used sparingly. If large areas require touch-up, replace the damaged area with new HardiePlank® lap siding with ColorPlus Technology.
- Laminate sheet must be removed immediately after installation of each course.
- Terminate non-factory cut edges into trim where possible, and caulk. Color matched caulks are available from your ColorPlus® product dealer.
- Treat all other non-factory cut edges using the ColorPlus Technology edge coat, available from your ColorPlus product dealer.

**Note:** James Hardie does not warrant the usage of third party touch-up or paints used as touch-up on James Hardie ColorPlus products.

Problems with appearance or performance arising from use of third party touch-up paints or paints used as touch-up that are not James Hardie touch-up, will not be covered under the James Hardie ColorPlus Limited Finish Warranty.

## PAINTING JAMES HARDIE® SIDING AND TRIM PRODUCTS WITH COLORPLUS® TECHNOLOGY

When repainting ColorPlus products, James Hardie recommends the following regarding surface preparation and topcoat application:

- Ensure the surface is clean, dry, and free of any dust, dirt, or mildew
- Repriming is normally not necessary
- 100% acrylic topcoats are recommended
- DO NOT use stain, oil/alkyd base paint, or powder coating on James Hardie® Products
- Apply finish coat in accordance with paint manufacturers written instructions regarding coverage, application methods, and application temperature
- DO NOT caulk nail heads when using ColorPlus products, refer to the ColorPlus touch-up section

RECOGNITION: HardieSoffit Panel complies with ASTM C1186 in so doing meets the Fiber-Cement Siding code requirements in the 2006 International Building Code® Section 1404.10 and 1405.15, the 2009/12 International Building Code Section 1404.10 and 1405.16 ; and the 2006/09/12 International Residential Code® for One- and Two-Family Dwellings Table R703.4 and section R703.10. HardieSoffit panel is also recognized for application in the following: State of Florida Product Approval FL13265, Dade County, Florida NOA No. 13-0311.07, U.S. Dept. of HUD Materials Release 1263, Texas Department of Insurance Product Evaluation EC-23, City of New York MEA 223-93-M, and California DSA PA-019. These documents should also be consulted for additional information concerning the suitability of this product for specific applications