

## Outset Window With 2x3 Framing Head Jamb



### InSoFast LLC Limits of Liability and Disclaimer of Warranty:

Because use conditions and applicable laws may differ from one location to another and may change with time, Customer is responsible for determining whether products and the information in this document are appropriate for use and are in compliance with applicable laws and other government enactments. InSoFast LLC assumes no obligation or liability for the information in this document. **NO WARRANTIES ARE GIVEN; ALL IMPLIED WARRANTIES OF MERCHANTABILITY OR FITNESS FOR A PARTICULAR PURPOSE ARE EXPRESSLY EXCLUDED. INSOFAST LLC SHALL NOT BE RESPONSIBLE FOR CONSEQUENTIAL, INDIRECT OR INCIDENTAL DAMAGES (INCLUDING LOSS OF PROFITS) OF ANY KIND.** InSoFast LLC reserves the right to make any changes according to technological progress or further developments and assumes no liability for providing such information and advice including the extent to which such information and advice may relate to existing third party intellectual property rights. Reference to trade names used by other companies is neither a recommendation, nor an endorsement of any product and does not imply that similar products could not be used. It is the responsibility of both the specifier and the purchaser to determine if a product is suitable for its intended use.

## Outset Window With 2x3 Framing Side Jamb

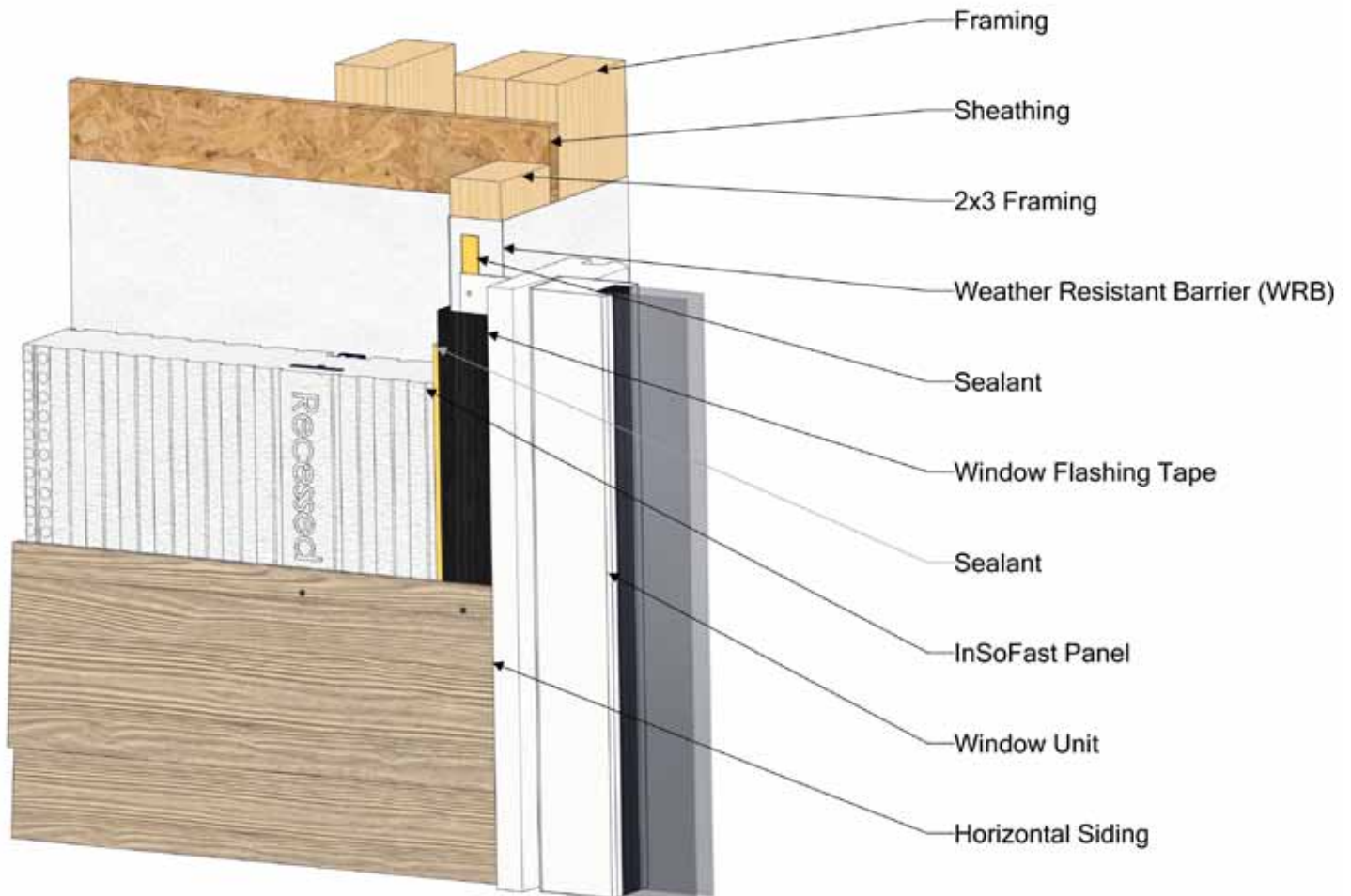

### InSoFast LLC Limits of Liability and Disclaimer of Warranty:

Because use conditions and applicable laws may differ from one location to another and may change with time, Customer is responsible for determining whether products and the information in this document are appropriate for use and are in compliance with applicable laws and other government enactments. InSoFast LLC assumes no obligation or liability for the information in this document. **NO WARRANTIES ARE GIVEN; ALL IMPLIED WARRANTIES OF MERCHANTABILITY OR FITNESS FOR A PARTICULAR PURPOSE ARE EXPRESSLY EXCLUDED. INSOFAST LLC SHALL NOT BE RESPONSIBLE FOR CONSEQUENTIAL, INDIRECT OR INCIDENTAL DAMAGES (INCLUDING LOSS OF PROFITS) OF ANY KIND.** InSoFast LLC reserves the right to make any changes according to technological progress or further developments and assumes no liability for providing such information and advice including the extent to which such information and advice may relate to existing third party intellectual property rights. Reference to trade names used by other companies is neither a recommendation, nor an endorsement of any product and does not imply that similar products could not be used. It is the responsibility of both the specifier and the purchaser to determine if a product is suitable for its intended use.

## Outset Window with 2x3 Framing Bottom Sill

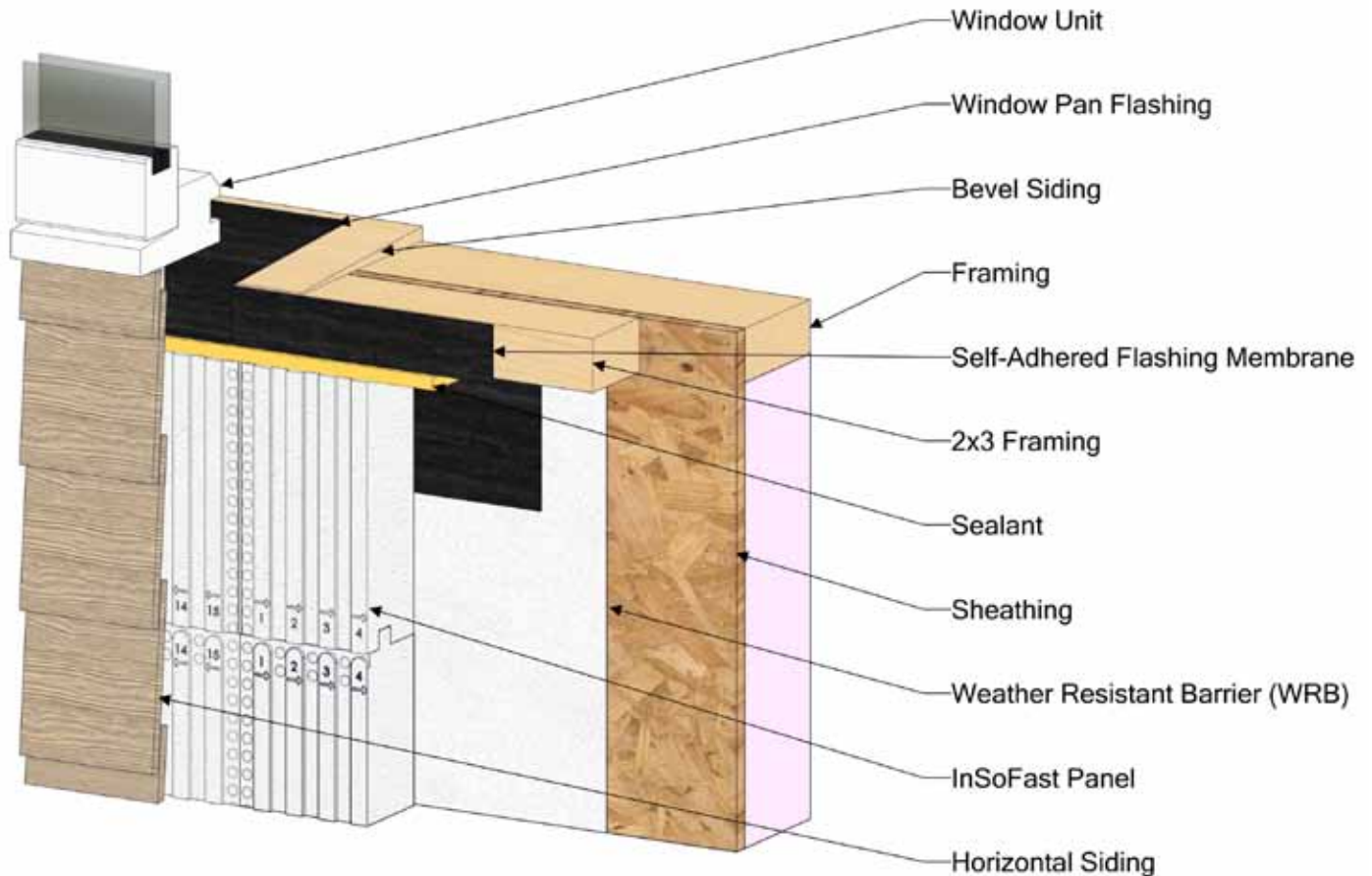

### InSoFast LLC Limits of Liability and Disclaimer of Warranty:

Because use conditions and applicable laws may differ from one location to another and may change with time, Customer is responsible for determining whether products and the information in this document are appropriate for use and are in compliance with applicable laws and other government enactments. InSoFast LLC assumes no obligation or liability for the information in this document. **NO WARRANTIES ARE GIVEN; ALL IMPLIED WARRANTIES OF MERCHANTABILITY OR FITNESS FOR A PARTICULAR PURPOSE ARE EXPRESSLY EXCLUDED. INSOFAST LLC SHALL NOT BE RESPONSIBLE FOR CONSEQUENTIAL, INDIRECT OR INCIDENTAL DAMAGES (INCLUDING LOSS OF PROFITS) OF ANY KIND.** InSoFast LLC reserves the right to make any changes according to technological progress or further developments and assumes no liability for providing such information and advice including the extent to which such information and advice may relate to existing third party intellectual property rights. Reference to trade names used by other companies is neither a recommendation, nor an endorsement of any product and does not imply that similar products could not be used. It is the responsibility of both the specifier and the purchaser to determine if a product is suitable for its intended use.

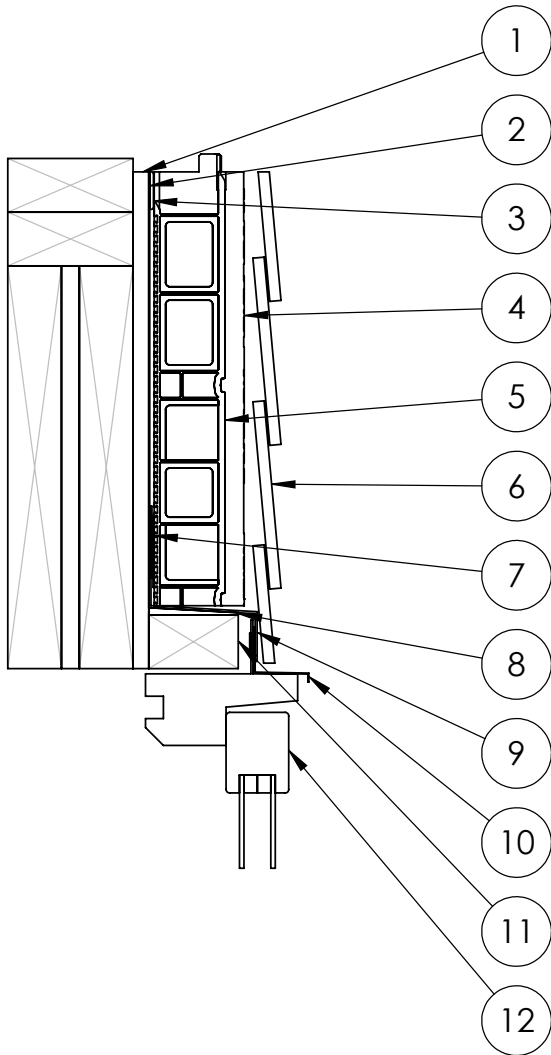

| #  | Description                     |
|----|---------------------------------|
| 1  | Sheathing                       |
| 2  | Weather Resistant Barrier (WRB) |
| 3  | Sealant                         |
| 4  | InSoFast Panel                  |
| 5  | InSoFast Integrated Stud        |
| 6  | Horizontal Siding               |
| 7  | Tape                            |
| 8  | Bevel Siding                    |
| 9  | Self-Adhered Flashing Membrane  |
| 10 | Metal Flashing                  |
| 11 | 2x3 Framing                     |
| 12 | Window Unit                     |

InSoFast LLC Limits of Liability and Disclaimer of Warranty: Because use conditions and applicable laws may differ from one location to another and may change with time, Customer is responsible for determining whether products and the information in this document are appropriate for use and are in compliance with applicable laws and other government enactments. InSoFast LLC assumes no obligation or liability for the information in this document. NO WARRANTIES ARE GIVEN; ALL IMPLIED WARRANTIES OF MERCHANTABILITY OR FITNESS FOR A PARTICULAR PURPOSE ARE EXPRESSLY EXCLUDED. INSOFAST LLC SHALL NOT BE RESPONSIBLE FOR CONSEQUENTIAL, INDIRECT OR INCIDENTAL DAMAGES (INCLUDING LOSS OF PROFITS) OF ANY KIND. InSoFast LLC reserves the right to make any changes according to technological progress or further developments and assumes no liability for providing such information and advice including the extent to which such information and advice may relate to existing third party intellectual property rights. Reference to trade names used by other companies is neither a recommendation, nor an endorsement of any product and does not imply that similar products could not be used. It is the responsibility of both the specifier and the purchaser to determine if a product is suitable for its intended use.



Outset Window With 2x3 Framing Head Jamb Section

888-501-7899 InSoFast, LLC www.InSoFast.com

Scale: not to scale

Date: 6/1/2017

Detail #: E-W-H-W-O-05

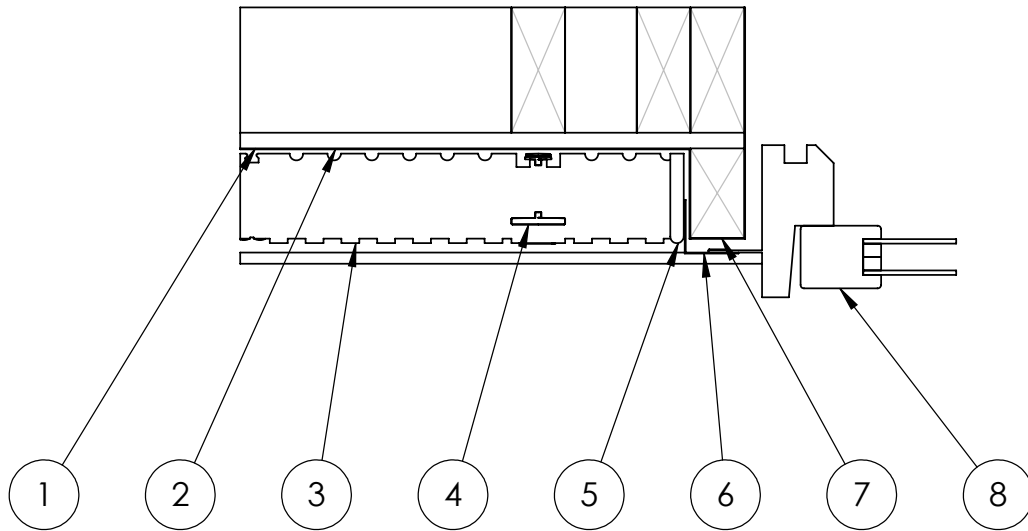

| # | Description                     |
|---|---------------------------------|
| 1 | Sheathing                       |
| 2 | Weather Resistant Barrier (WRB) |
| 3 | InSoFast Panel                  |
| 4 | InSoFast Integrated Stud        |
| 5 | Sealant                         |
| 6 | Window Flashing Tape            |
| 7 | 2x3 Framing                     |
| 8 | Window Unit                     |

InSoFast LLC Limits of Liability and Disclaimer of Warranty: Because use conditions and applicable laws may differ from one location to another and may change with time, Customer is responsible for determining whether products and the information in this document are appropriate for use and are in compliance with applicable laws and other government enactments. InSoFast LLC assumes no obligation or liability for the information in this document. NO WARRANTIES ARE GIVEN; ALL IMPLIED WARRANTIES OF MERCHANTABILITY OR FITNESS FOR A PARTICULAR PURPOSE ARE EXPRESSLY EXCLUDED. INSOFAST LLC SHALL NOT BE RESPONSIBLE FOR CONSEQUENTIAL, INDIRECT OR INCIDENTAL DAMAGES (INCLUDING LOSS OF PROFITS) OF ANY KIND. InSoFast LLC reserves the right to make any changes according to technological progress or further developments and assumes no liability for providing such information and advice including the extent to which such information and advice may relate to existing third party intellectual property rights. Reference to trade names used by other companies is neither a recommendation, nor an endorsement of any product and does not imply that similar products could not be used. It is the responsibility of both the specifier and the purchaser to determine if a product is suitable for its intended use.



Outset Window With 2x3 Framing Horizontal Section

888-501-7899 InSoFast, LLC www.InSoFast.com

Scale: not to scale

Date: 6/1/2017

Detail #: E-W-H-W-O-04

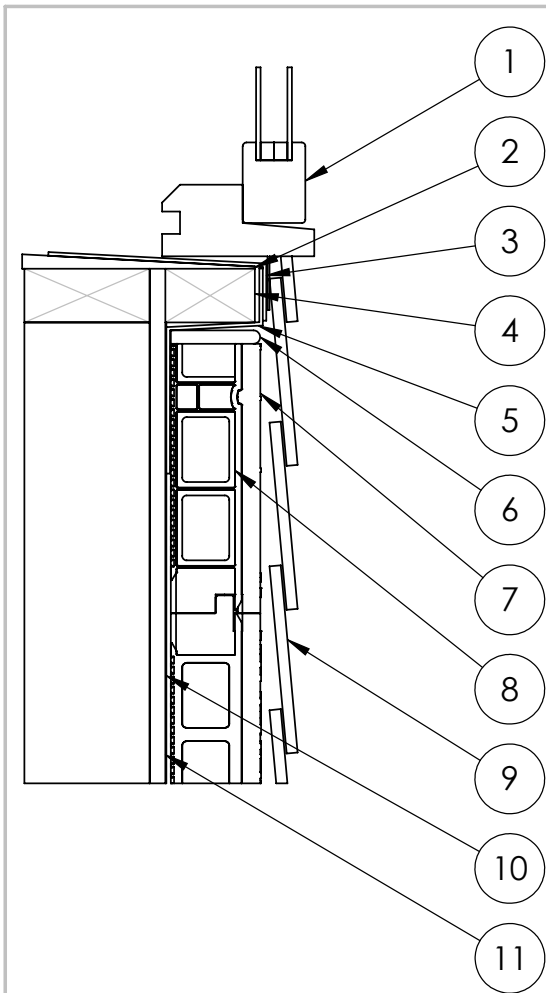

| #  | Description                     |
|----|---------------------------------|
| 1  | Window Unit                     |
| 2  | Bevel Siding                    |
| 3  | Window Pan Flashing             |
| 4  | 2x3 Framing                     |
| 5  | Self-Adhered Flashing Membrane  |
| 6  | Sealant                         |
| 7  | InSoFast Panel                  |
| 8  | InSoFast Integrated Stud        |
| 9  | Horizontal Siding               |
| 10 | Weather Resistant Barrier (WRB) |
| 11 | Sheathing                       |

InSoFast LLC Limits of Liability and Disclaimer of Warranty: Because use conditions and applicable laws may differ from one location to another and may change with time, Customer is responsible for determining whether products and the information in this document are appropriate for use and are in compliance with applicable laws and other government enactments. InSoFast LLC assumes no obligation or liability for the information in this document. NO WARRANTIES ARE GIVEN; ALL IMPLIED WARRANTIES OF MERCHANTABILITY OR FITNESS FOR A PARTICULAR PURPOSE ARE EXPRESSLY EXCLUDED. INSOFAST LLC SHALL NOT BE RESPONSIBLE FOR CONSEQUENTIAL, INDIRECT OR INCIDENTAL DAMAGES (INCLUDING LOSS OF PROFITS) OF ANY KIND. InSoFast LLC reserves the right to make any changes according to technological progress or further developments and assumes no liability for providing such information and advice including the extent to which such information and advice may relate to existing third party intellectual property rights. Reference to trade names used by other companies is neither a recommendation, nor an endorsement of any product and does not imply that similar products could not be used. It is the responsibility of both the specifier and the purchaser to determine if a product is suitable for its intended use.



Outset Window With 2x3 Framing Sill Section  
 888-501-7899 InSoFast, LLC www.InSoFast.com

Scale: not to scale  
 Date: 6/1/2017  
 Detail #: E-W-H-W-O-06

## InSoFast EX 2.5 with Outset Window



### InSoFast LLC Limits of Liability and Disclaimer of Warranty:

Because use conditions and applicable laws may differ from one location to another and may change with time, Customer is responsible for determining whether products and the information in this document are appropriate for use and are in compliance with applicable laws and other government enactments. InSoFast LLC assumes no obligation or liability for the information in this document. **NO WARRANTIES ARE GIVEN; ALL IMPLIED WARRANTIES OF MERCHANTABILITY OR FITNESS FOR A PARTICULAR PURPOSE ARE EXPRESSLY EXCLUDED. INSOFAST LLC SHALL NOT BE RESPONSIBLE FOR CONSEQUENTIAL, INDIRECT OR INCIDENTAL DAMAGES (INCLUDING LOSS OF PROFITS) OF ANY KIND.** InSoFast LLC reserves the right to make any changes according to technological progress or further developments and assumes no liability for providing such information and advice including the extent to which such information and advice may relate to existing third party intellectual property rights. Reference to trade names used by other companies is neither a recommendation, nor an endorsement of any product and does not imply that similar products could not be used. It is the responsibility of both the specifier and the purchaser to determine if a product is suitable for its intended use.

## Outset Window - Head Jamb

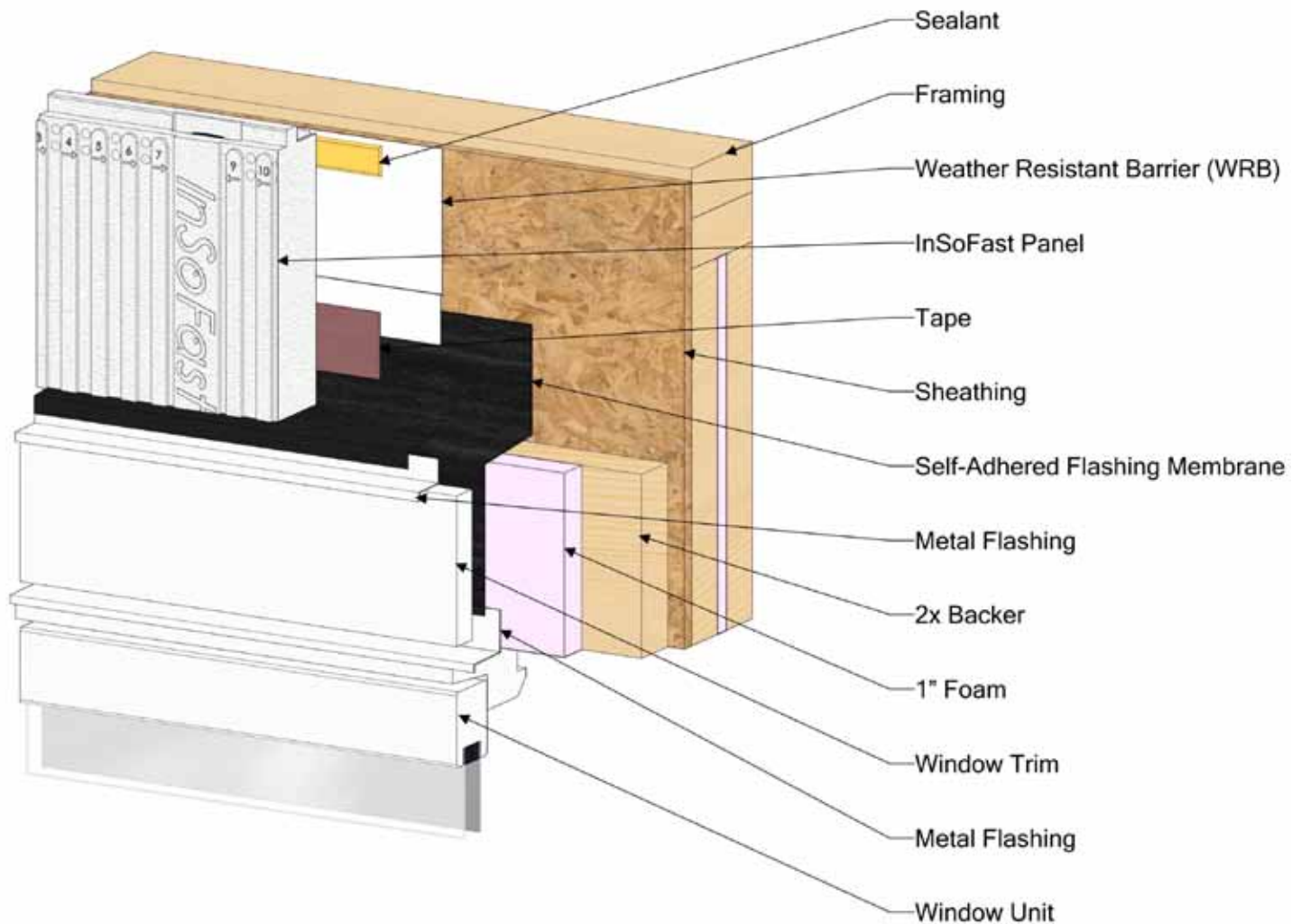

### InSoFast LLC Limits of Liability and Disclaimer of Warranty:

Because use conditions and applicable laws may differ from one location to another and may change with time, Customer is responsible for determining whether products and the information in this document are appropriate for use and are in compliance with applicable laws and other government enactments. InSoFast LLC assumes no obligation or liability for the information in this document. **NO WARRANTIES ARE GIVEN; ALL IMPLIED WARRANTIES OF MERCHANTABILITY OR FITNESS FOR A PARTICULAR PURPOSE ARE EXPRESSLY EXCLUDED. INSOFAST LLC SHALL NOT BE RESPONSIBLE FOR CONSEQUENTIAL, INDIRECT OR INCIDENTAL DAMAGES (INCLUDING LOSS OF PROFITS) OF ANY KIND.** InSoFast LLC reserves the right to make any changes according to technological progress or further developments and assumes no liability for providing such information and advice including the extent to which such information and advice may relate to existing third party intellectual property rights. Reference to trade names used by other companies is neither a recommendation, nor an endorsement of any product and does not imply that similar products could not be used. It is the responsibility of both the specifier and the purchaser to determine if a product is suitable for its intended use.



## Outset Window - Side Jamb

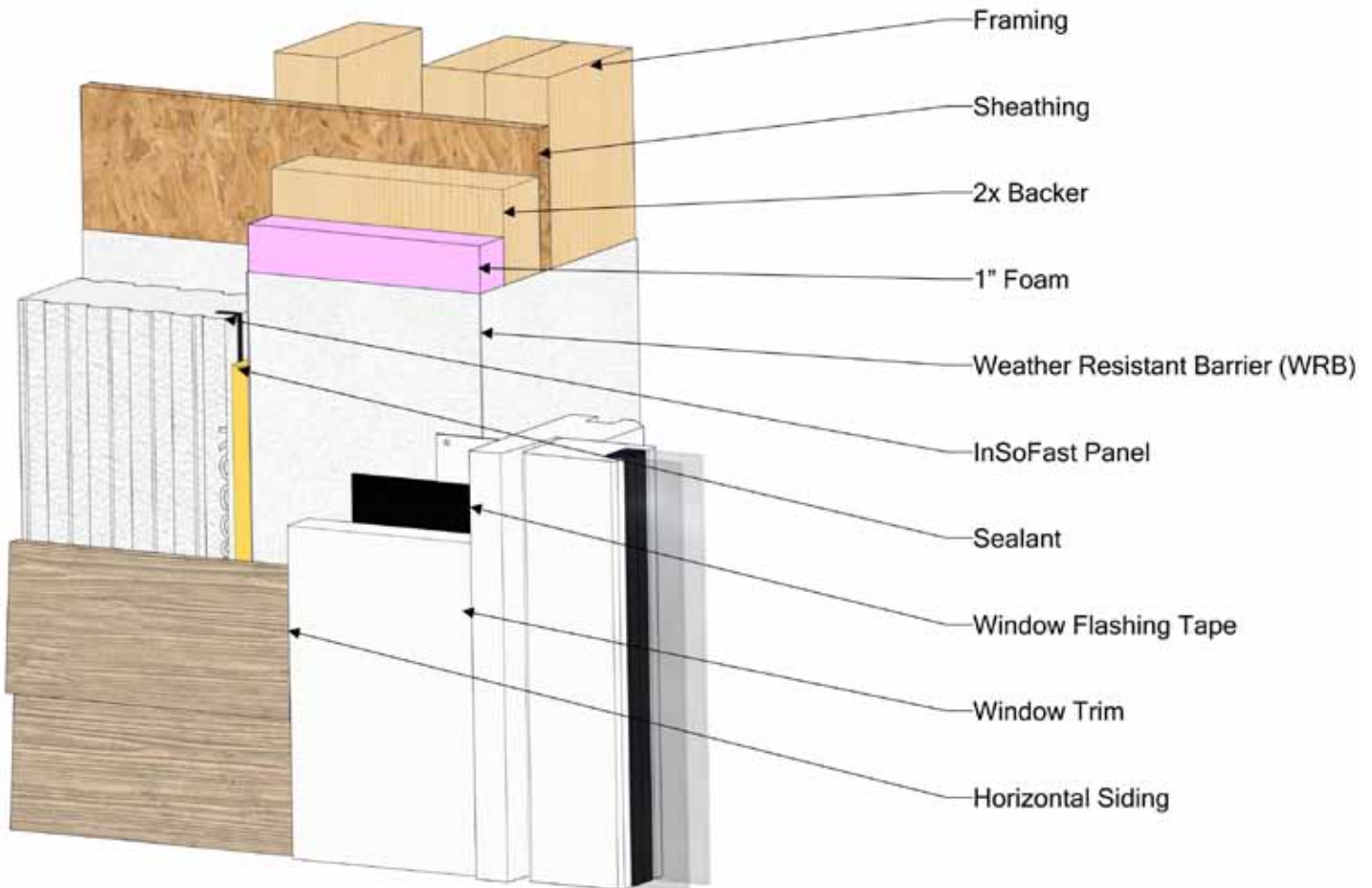

### InSoFast LLC Limits of Liability and Disclaimer of Warranty:

Because use conditions and applicable laws may differ from one location to another and may change with time, Customer is responsible for determining whether products and the information in this document are appropriate for use and are in compliance with applicable laws and other government enactments. InSoFast LLC assumes no obligation or liability for the information in this document. **NO WARRANTIES ARE GIVEN; ALL IMPLIED WARRANTIES OF MERCHANTABILITY OR FITNESS FOR A PARTICULAR PURPOSE ARE EXPRESSLY EXCLUDED. INSOFAST LLC SHALL NOT BE RESPONSIBLE FOR CONSEQUENTIAL, INDIRECT OR INCIDENTAL DAMAGES (INCLUDING LOSS OF PROFITS) OF ANY KIND.** InSoFast LLC reserves the right to make any changes according to technological progress or further developments and assumes no liability for providing such information and advice including the extent to which such information and advice may relate to existing third party intellectual property rights. Reference to trade names used by other companies is neither a recommendation, nor an endorsement of any product and does not imply that similar products could not be used. It is the responsibility of both the specifier and the purchaser to determine if a product is suitable for its intended use.

## Outset Window - Bottom Sill

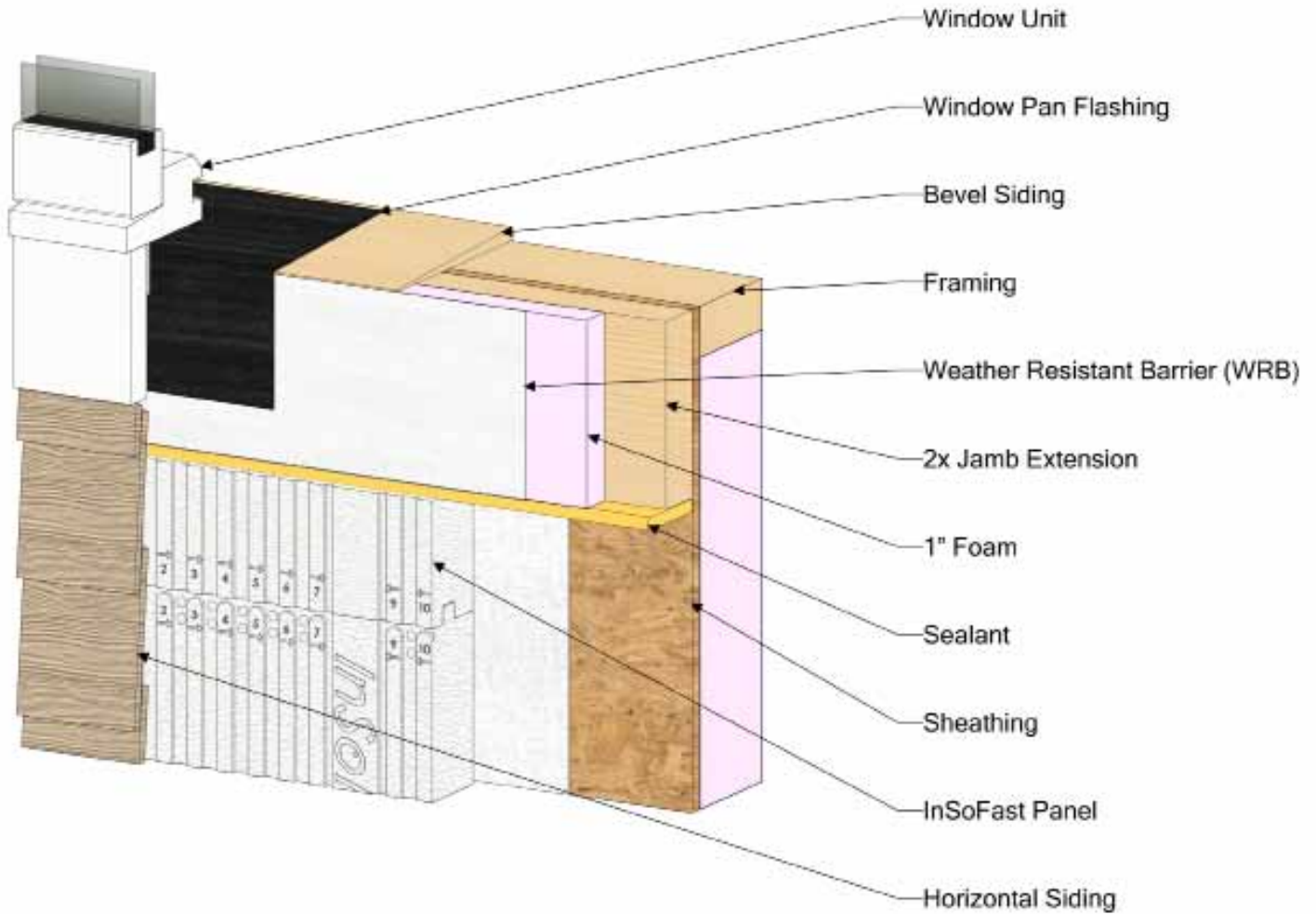

### InSoFast LLC Limits of Liability and Disclaimer of Warranty:

Because use conditions and applicable laws may differ from one location to another and may change with time, Customer is responsible for determining whether products and the information in this document are appropriate for use and are in compliance with applicable laws and other government enactments. InSoFast LLC assumes no obligation or liability for the information in this document. **NO WARRANTIES ARE GIVEN; ALL IMPLIED WARRANTIES OF MERCHANTABILITY OR FITNESS FOR A PARTICULAR PURPOSE ARE EXPRESSLY EXCLUDED. INSOFAST LLC SHALL NOT BE RESPONSIBLE FOR CONSEQUENTIAL, INDIRECT OR INCIDENTAL DAMAGES (INCLUDING LOSS OF PROFITS) OF ANY KIND.** InSoFast LLC reserves the right to make any changes according to technological progress or further developments and assumes no liability for providing such information and advice including the extent to which such information and advice may relate to existing third party intellectual property rights. Reference to trade names used by other companies is neither a recommendation, nor an endorsement of any product and does not imply that similar products could not be used. It is the responsibility of both the specifier and the purchaser to determine if a product is suitable for its intended use.

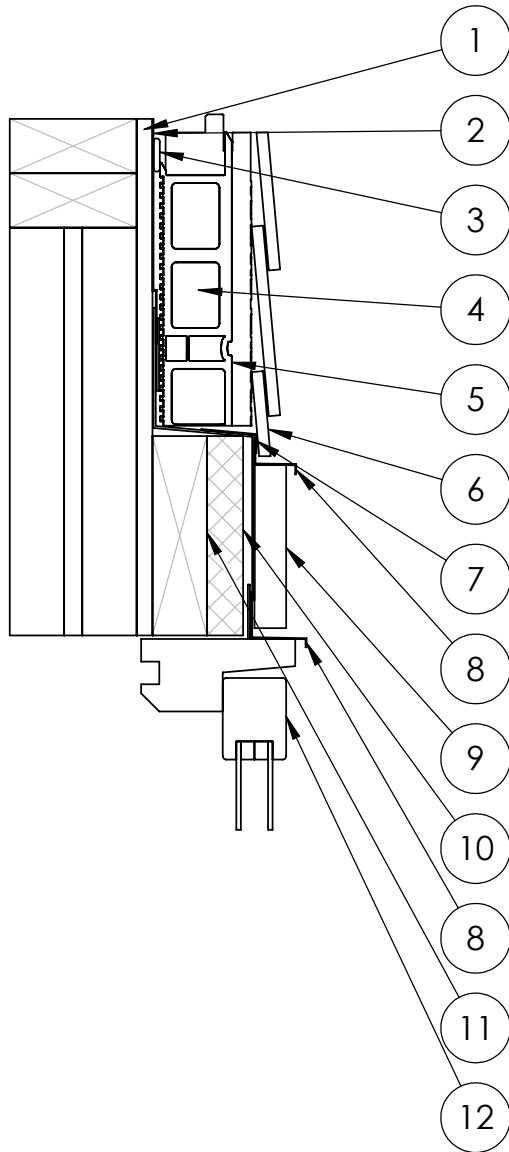

| #  | Description                     |
|----|---------------------------------|
| 1  | Sheathing                       |
| 2  | Weather Resistant Barrier (WRB) |
| 3  | Sealant                         |
| 4  | InSoFast Panel                  |
| 5  | InSoFast Integrated Stud        |
| 6  | Horizontal Siding               |
| 7  | Self-Adhered Flashing Membrane  |
| 8  | Metal Flashing                  |
| 9  | Window Trim                     |
| 10 | 1" Foam                         |
| 11 | 2x Backer                       |
| 12 | Window Unit                     |

InSoFast LLC Limits of Liability and Disclaimer of Warranty: Because use conditions and applicable laws may differ from one location to another and may change with time, Customer is responsible for determining whether products and the information in this document are appropriate for use and are in compliance with applicable laws and other government enactments. InSoFast LLC assumes no obligation or liability for the information in this document. NO WARRANTIES ARE GIVEN; ALL IMPLIED WARRANTIES OF MERCHANTABILITY OR FITNESS FOR A PARTICULAR PURPOSE ARE EXPRESSLY EXCLUDED. INSOFAST LLC SHALL NOT BE RESPONSIBLE FOR CONSEQUENTIAL, INDIRECT OR INCIDENTAL DAMAGES (INCLUDING LOSS OF PROFITS) OF ANY KIND. InSoFast LLC reserves the right to make any changes according to technological progress or further developments and assumes no liability for providing such information and advice including the extent to which such information and advice may relate to existing third party intellectual property rights. Reference to trade names used by other companies is neither a recommendation, nor an endorsement of any product and does not imply that similar products could not be used. It is the responsibility of both the specifier and the purchaser to determine if a product is suitable for its intended use.



**InSoFast**

Outset Window Head Jamb Section

888-501-7899 InSoFast, LLC www.InSoFast.com

Scale: not to scale

Date: 4/22/2017

Detail #: E-W-H-W-O-02

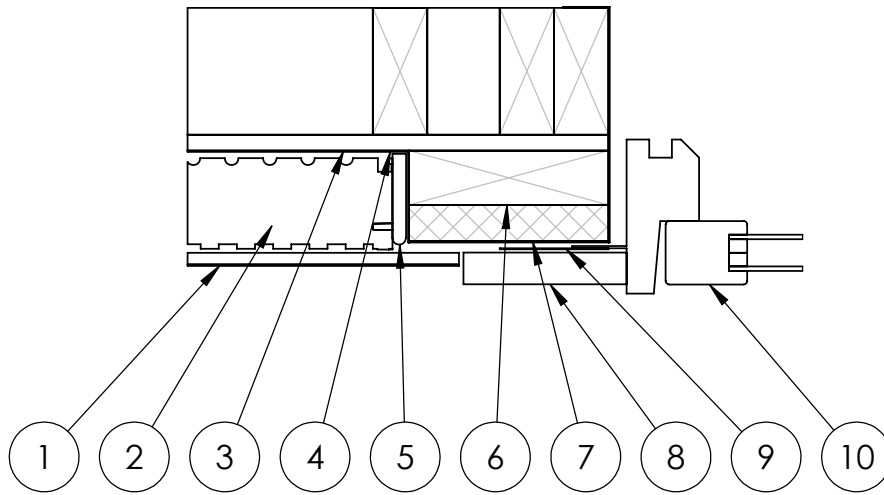

| #  | Description                     |
|----|---------------------------------|
| 1  | Horizontal Siding               |
| 2  | InSoFast Panel                  |
| 3  | Weather Resistant Barrier (WRB) |
| 4  | Sheathing                       |
| 5  | Sealant                         |
| 6  | 2x Backer                       |
| 7  | 1" Foam                         |
| 8  | Window Trim                     |
| 9  | Window Flashing Tape            |
| 10 | Window Unit                     |

InSoFast LLC Limits of Liability and Disclaimer of Warranty: Because use conditions and applicable laws may differ from one location to another and may change with time, Customer is responsible for determining whether products and the information in this document are appropriate for use and are in compliance with applicable laws and other government enactments. InSoFast LLC assumes no obligation or liability for the information in this document. NO WARRANTIES ARE GIVEN; ALL IMPLIED WARRANTIES OF MERCHANTABILITY OR FITNESS FOR A PARTICULAR PURPOSE ARE EXPRESSLY EXCLUDED. INSOFAST LLC SHALL NOT BE RESPONSIBLE FOR CONSEQUENTIAL, INDIRECT OR INCIDENTAL DAMAGES (INCLUDING LOSS OF PROFITS) OF ANY KIND. InSoFast LLC reserves the right to make any changes according to technological progress or further developments and assumes no liability for providing such information and advice including the extent to which such information and advice may relate to existing third party intellectual property rights. Reference to trade names used by other companies is neither a recommendation, nor an endorsement of any product and does not imply that similar products could not be used. It is the responsibility of both the specifier and the purchaser to determine if a product is suitable for its intended use.



Outset Window Horizontal Section  
 888-501-7899 InSoFast, LLC www.InSoFast.com

Scale: not to scale  
 Date: 4/22/2017  
 Detail #: E-W-H-W-O-01

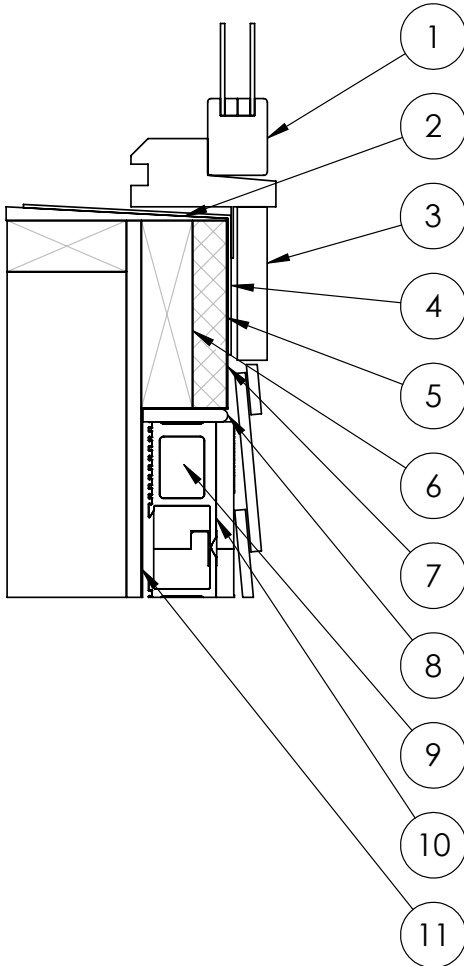

| #  | Description                     |
|----|---------------------------------|
| 1  | Window Unit                     |
| 2  | Bevel Siding                    |
| 3  | Window Trim                     |
| 4  | Window Pan Flashing             |
| 5  | 1" Foam                         |
| 6  | 2x Backer                       |
| 7  | Weather Resistant Barrier (WRB) |
| 8  | Sealant                         |
| 9  | InSoFast Panel                  |
| 10 | InSoFast Integrated Stud        |
| 11 | Sheathing                       |

InSoFast LLC Limits of Liability and Disclaimer of Warranty: Because use conditions and applicable laws may differ from one location to another and may change with time, Customer is responsible for determining whether products and the information in this document are appropriate for use and are in compliance with applicable laws and other government enactments. InSoFast LLC assumes no obligation or liability for the information in this document. NO WARRANTIES ARE GIVEN; ALL IMPLIED WARRANTIES OF MERCHANTABILITY OR FITNESS FOR A PARTICULAR PURPOSE ARE EXPRESSLY EXCLUDED. INSOFast LLC SHALL NOT BE RESPONSIBLE FOR CONSEQUENTIAL, INDIRECT OR INCIDENTAL DAMAGES (INCLUDING LOSS OF PROFITS) OF ANY KIND. InSoFast LLC reserves the right to make any changes according to technological progress or further developments and assumes no liability for providing such information and advice including the extent to which such information and advice may relate to existing third party intellectual property rights. Reference to trade names used by other companies is neither a recommendation, nor an endorsement of any product and does not imply that similar products could not be used. It is the responsibility of both the specifier and the purchaser to determine if a product is suitable for its intended use.



Outset Window Sill Section  
 888-501-7899 InSoFast, LLC www.InSoFast.com

Scale: not to scale  
 Date: 4/22/2017  
 Detail #: E-W-H-W-O-03